

BNC - Crimp Connector Termination

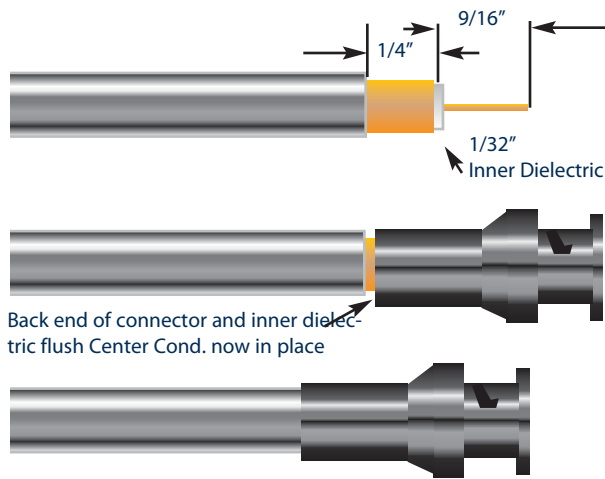

Twist On BNC Connector

1. Trim cable as shown, taking care not to nick the center conductor or outer braid.
2. Twist the outer braid in a clockwise direction in such a manner that at least $1/32$ " of the inner dielectric is bared, and the braid is left flat. (Stray or loose braid can cause shorts).
3. Gently insert the center conductor down into the back end of the connector, feeling it into the guide hole. When the center conductor is not in place approx. $1/8$ " of center conductor will show.
4. Firmly push the cable home as far as possible. Then screw the connector on the cable in a clockwise direction until it stops.

2 Piece BNC Connector

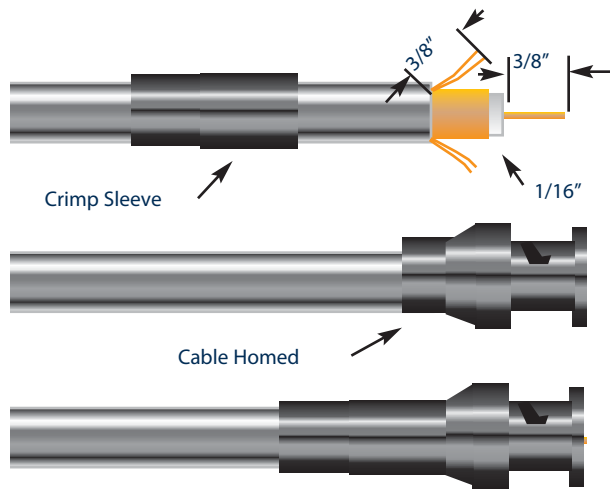

1. Run crimp sleeve down cable.
2. Trim cable as shown. Taking care not to nick the center conductor or outer braid
3. Gently insert the center conductor into the guide hole, in the rear of the connector, and firmly push the cable home.
4. Push crimp sleeve into place. Sandwiching the braid between the connector and sleeve.
5. Crimp the sleeve into place with the proper crimp tool.

3 Piece BNC Connector

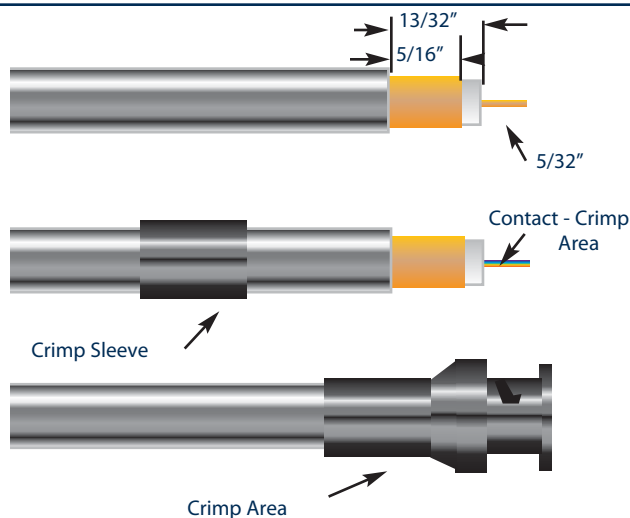

1. Trim cable as shown. Taking care not to nick the center conductor or outer braid. For Miniature Coaxial Cable we recommend - TL-KLEIN
2. Slip crimp sleeve over cable. Place inner conductor into contact, note that the end of the contact and inner dielectric must be butting and square. Crimp with proper crimp tool.
3. Flair outer braid, and gently but firmly push the contact into the connector housing until a gentle snap is felt. Indicating the contact is in place. Slip the crimp sleeve in place, butting the flange against the connector body, and crimp with proper tooling.

Technical Reference

Compression- Connector Termination



Using TL-SNSA Adjustment of the tool for BNC, RCA, & "F" Connector Types

BNC

BNC- Compression for Window Style Connectors

Set tool at 3

CN-BNCP-RGB

CN-BNCP-825

CN-BNCP-59

CN-BNCP-6

BNC- Compression for Longer Style Connectors

Set tool at 10

CN-FS1BNC

CN-FS59BNCPL4

CN-FS6BNCPL2

RCA

RCA- Compression for Window Style Connectors

Set tool at 3

CN-RCP-RGB

CN-RCP-825

CN-RCP-59

CN-RCP-6

RCA- Compression for Longer Style Connectors

Set tool at 1

CN-FS1RCA

CN-FS59RCAPL4

CN-FS6RCAPL2

"F"

"F" Compression for both types of compression connectors:

Set tool at 0.

NOTE: THERE MAYBE IN THE FIELD ADJUSTMENTS TO THE TOOLS FOR COMPLETE FUNCTIONING.