

# Fire Alarm Cables

**Life. Safety.** Fire alarm systems serve as life lines to safe and secure buildings. As one of the original manufacturers of fire alarm cable, West Penn Wire knows proper cable selection is critical to effective system performance. With over 100 variations of cable constructions, environmental ratings, colors, and striping options, we have the right fire alarm cable. Match the right cable to system demand and ensure a safe building.

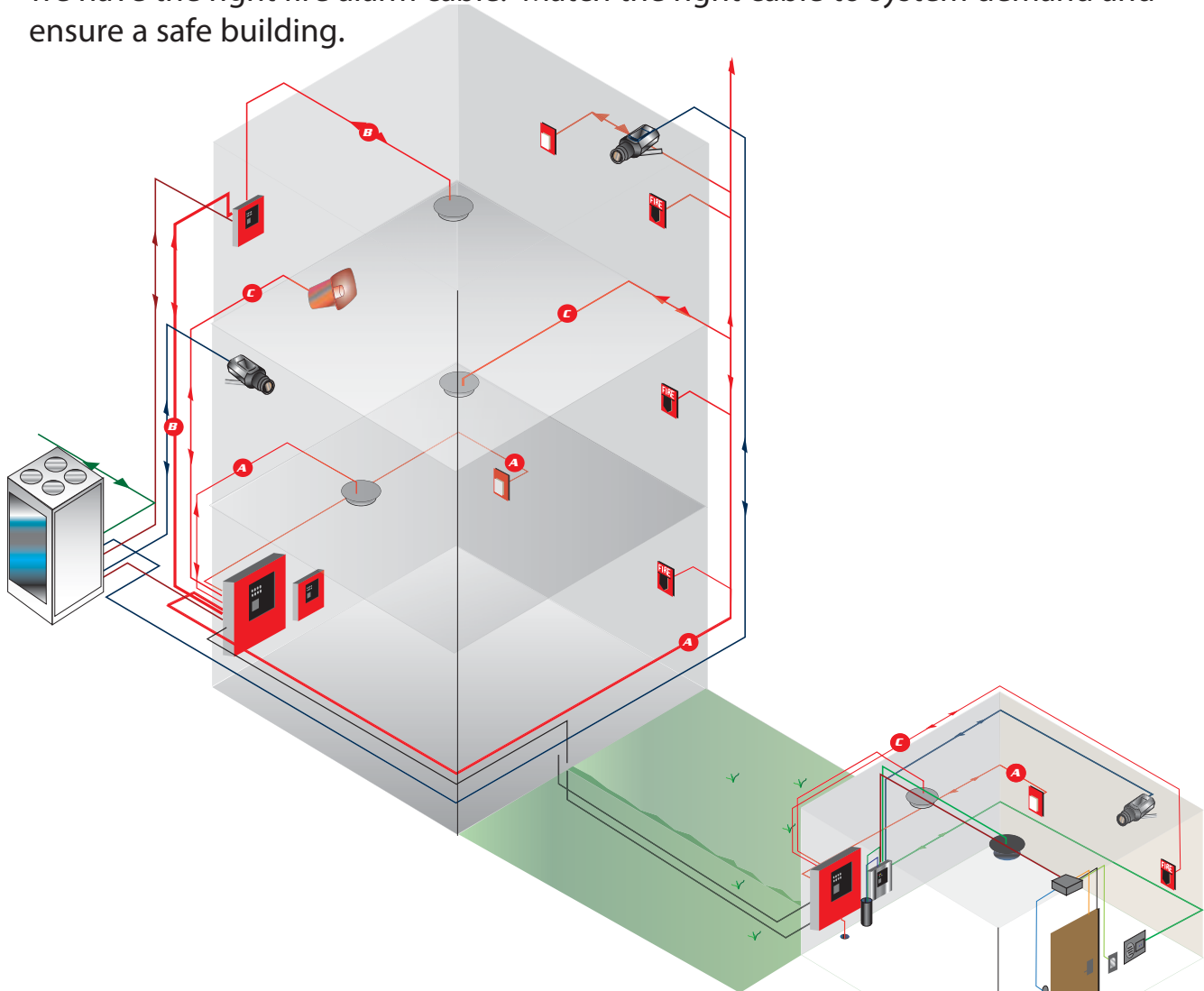

## FEATURES

- Solid Conductor Constructions
- Stranded Conductor Constructions
- Power Limited Data Grade Designs
- Available in Multiple Jacket Colors
- Available with Strips
- Circuit Integrity Designs
- Local Law 5 (NYC) Designs
- Indoor/Outdoor Design in Aquaseal Section-

800-245-4964 • [www.westpenn-wpw.com](http://www.westpenn-wpw.com)

# Fire Alarm Cables

**WEST PENN WIRE**

**UNSHIELDED FIRE ALARM CABLES**

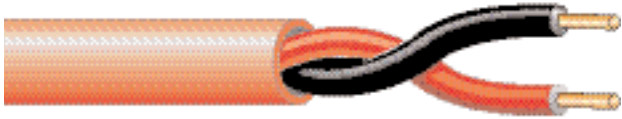

## UNSHIELDED FIRE ALARM CABLES

AWG Size	# of Cond.	FPL			FPLR	FPLP	NPLF	NPLFP	FPLR-CIC	FPLR-CI
		Aquaseal	Low Cap	Parallel	Mid-Cap	Mid-Cap	Mid-Cap	Mid-Cap	Mid-Cap	Mid-Cap
12 Solid	2			974	998	60995B			5020UZ	5020UM
14 Solid	2			972	994	60993B	1994	251994	5120UZ	5120UM
14 Solid	4				700	60700B				5122UM
16 Solid	2		D990	971	990	60991B	1990		5220UZ	5220UM
16 Solid	4				992	60164B				5222UM
18 Solid	2		D980	970	980	60980B		251980		5320UM
18 Solid	4		D982		982	60992B				5322UM
12 Strd	2	AQ227			998S				5000UZ	
14 Strd	2	AQ226			994S				5100UZ	
14 Strd	4	AQ246								
16 Strd	2	AQ225			990S				5200UZ	
16 Strd	4	AQ245								
18 Strd	2	AQ224								
18 Strd	4	AQ244								

**SHIELDED FIRE ALARM CABLES**

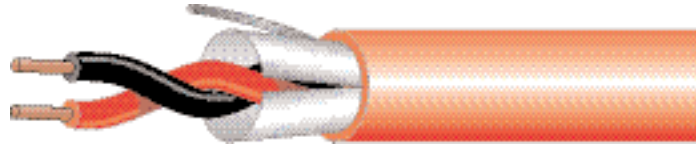

## SHIELDED FIRE ALARM CABLES

AWG Size	# of Cond.	FPL		FPLR	FPLP		NPLF	NPLFP	FPLR-CIC	FPLR-CI
		Aquaseal	Low Cap	Mid-Cap	Mid-Cap	Low-Cap	Mid-Cap	Mid-Cap	Mid-Cap	Mid-Cap
12 Solid	2			999	60994B		1999		5020FZ	5020FM
12 Solid	4								5022FZ	5022FM
14 Solid	2		D995	995	60992B		1995	251995	5120FZ	5120FM
14 Solid	4						1997			5122FM
16 Solid	2		D991	991	60990B	D60990	1991	251991	5220FZ	5220FM
16 Solid	4			993	603164B				5222FZ	5222FM
18 Solid	2		D975	975	60975B	D60975	1975	251975		5320FM
18 Solid	4			977	60977B					5322FM
12 Strd	2	AQ296							5000FZ	
14 Strd	2	AQ295							5100FZ	5100FM
14 Strd	4								5200FZ	
16 Strd	2	AQ294								5200FM
16 Strd	4	AQ3245								
18 Strd	2	AQ293								5300FM
18 Strd	4	AQ3244								

## ***FIRE ALARM SYSTEMS AND CABLE:***

West Penn Wire is the leading manufacturer of fire alarm system cables for the fire protection industry. Our innovative product line includes all power-limited and non-power limited cables for use in the NEC Article 760. West Penn Wire includes Aquaseal power-limited fire alarm system cables. Aquaseal Water-Resistant cable is a trademark for the industry's original indoor/outdoor low-capacitance fire alarm system cables.

NATIONAL ELECTRIC CODE (NEC) ARTICLE 760: NEC Article 760 covers the installation of wiring and equipment of fire alarm systems, including all circuits controlled and powered by the fire alarm system. These systems are defined in the NEC as "The portion of the wiring system between the load side of the overcurrent devices or the power-limited supply and the connected equipment of all circuits powered and controlled by the fire alarm system."

### ***POWER-LIMITED FIRE ALARM SYSTEM CABLES:***

***Three types of power-limited fire alarm cables are currently in use.***

1. Type FPL- FPL power-limited fire alarm cable is listed by the NEC as being suitable for general purpose fire alarm use. This listing excludes installation in riser, ducts, plenums and other space used for environmental air unless the cable is installed in conduit. All FPL cables are listed as being resistant to the spread of fire and must pass both UL test 1424 and the vertical flame test UL 1581.

2. Type FPLR- FPLR power-limited fire alarm riser cable is listed as being suitable for use in a vertical run in a shaft or from floor to floor. All FPLR cables are listed as having fire-resistant characteristics capable of preventing fire from traveling from floor to floor. Riser cables must pass both UL test 1424 and the Vertical riser test UL 1666.

3. Type FPLP- FPLP power-limited fire alarm cable is listed by the NEC as being suitable for use in ducts, plenums and other space used for environmental air. All FPLP cables are listed as having adequate fire resistant and low-smoke producing characteristics and must pass both UL test 1424 and UL Stiner tunnel test 910. (NFPA 262)

- No Voltage Rating Markings on PLFA Cables
- CL3 and CM rated cables, which have a voltage rating of 300V are permitted to be used as PLFA cables.
- Power-limited is inherently limited by the power supply
  - Transformer
  - Other Power Supply Devices

### ***NON POWER-LIMITED FIRE ALARM SYSTEM CABLES:***

1. Type NPLF- NPLF Non power-limited fire alarm cable is listed by the NEC as being suitable for general purpose fire alarm use. This listing excludes installation in riser, ducts, plenums and other space used for environmental air unless the cable is installed in conduit. All NPLF cables are listed as being resistant to the spread of fire and must pass both UL test 1424 and the vertical flame test UL 1581.

2. Type NPLFP- NPLFP Non power-limited fire alarm cable is listed by the NEC as being suitable for use in ducts, plenums and other space used for environmental air. All NPLFP cables are listed as having adequate fire resistant and low-smoke-producing characteristics and must pass both UL test 1424 and UL Stiner tunnel test 910. (NFPA 262)

- Power source of NPLFA circuits output voltage shall not exceed 600 volts. Nominal
- Marking on NPLF cables are not addressed as 150V. For use in 150V or less on NPLF circuits (out of tray or conduit)
- Class 1 cables can be installed and used as NPLFA, but must be placed in a tray or conduit. • Overcurrent devices shall be located at the point where the device to be protected receives its supply.

## CONVENTIONAL ( STANDARD) FIRE ALARM SYSTEM

Conventional Fire Alarm Systems, in their various forms, have been around for many of years and have changed little in that time in terms of technology although design and reliability have improved significantly. However, Conventional systems are a well proven technology protecting many hundreds of thousands of properties worldwide. A Conventional Fire Alarm System is often the natural choice for smaller systems or where budget constraints exist.

In a Conventional Fire Alarm System the "Intelligence" of the system resides solely within the Fire Alarm Control Panel. The panel receives a trigger signal from a Conventional Detector or Initiating Device Circuit (Smoke, heat, flame detectors) which in turn signals the condition to the Notification (Indicating) Device Circuit such as alarm sounders, horns, strobes and other remote signalling equipment.

Conventional detectors are normally connected to the Fire Control Panel via dedicated circuits, each circuit protecting a designated "Zone" or area of the building. The system has different modes: Normal, Alarm, Trouble, and others, depending on the Fire Alarm Manufacturer.

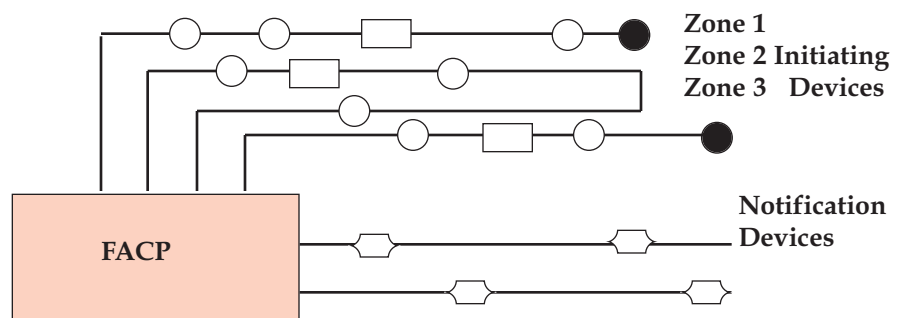

## CONVENTIONAL FIRE ALARM CABLE SELECTION

The designer must be sure that the last device on the circuit has sufficient voltage to operate the device within its rated voltage. When calculating the voltage available to the last device, it is necessary to consider the voltage drop due to the resistance of the wire. The larger the wire, the less the voltage drop. Generally, for purposes of determining the wire size necessary for the system, it is best to consider all of the devices as "lumped" on the end of the supply circuit, this simulates the worst case.

### Typical wire size resistance:

Wire Size	Approximate Resistance	Loop Resistance
18 AWG solid:	Approximately 6.5ohms/1000ft.	13ohms/1000ft.
16 AWG solid:	Approximately 4.1ohms/1000ft.	8.2ohms/1000ft.
14 AWG solid:	Approximately 2.6ohms/1000ft.	5.2ohms/1000ft.
12 AWG solid:	Approximately 1.8ohms/1000ft.	3.6ohms/1000ft.

### EXAMPLE:

Assume you have 10 devices on a zone and each require 50mA average and 2000ft. of 14 AWG wiring. The voltage drop at the end of the loop is .050 amps per device x 10 devices x 2.6/1000ft x 2000 = 2.6 V. A 12 AWG would produce a drop 1.8 V, and a 18 AWG would produce a voltage drop of 6.5 V.

### Notes:

- If Class A wiring is installed, the wire length may be up to 4 times the single wire length in this calculation. Consult your panel manufacturer's specifications to determine acceptable voltage drop. Do not exceed panels specified amperage output. All wiring must be installed in compliance with the National Electrical Code (NEC) and applicable local codes, as well as special requirements of the authority having jurisdiction, using the proper wire size.

## **CONVENTIONAL FIRE ALARM SYSTEM CABLES**

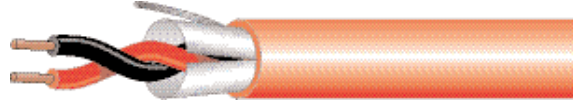

### **(POWER-LIMITED) CONVENTIONAL FIRE ALARM SYSTEM CABLES:**

- CONDUCTOR-
- Shall not be smaller in size than a 26 AWG.
  - Single conductor no smaller than 18 AWG.
  - Solid or Stranded conductor. Bare Copper for lower DC Resistance.

- INSULATION (DIELECTRIC)-
- PVC Insulation for the FPLR cables
  - Fire/ Smoke Retardant PVC for the FPLP - West PennWire "B" Series
  - Fluoropolymer Insulation for the FPLP - Non "B" Series.

CONDUCTORS ARE EITHER TWISTED CABLED OR PARALLEL.

- SHIELD-
- (OPTIONAL) DEPENDANT ON SYSTEM REQUIREMENTS, AND ENVIRONMENTAL CONDITIONS -
- To protect against interference created from other cables or other electronic/electrical/ Mechanical devices.
  - The shield is a 100% Aluminium foiled wrap.

- JACKET-
- PVC Jacket for the FPLR cables
- Flexible Plenum PVC jacket for the FPLP cables.
  - The jacket is usually Red

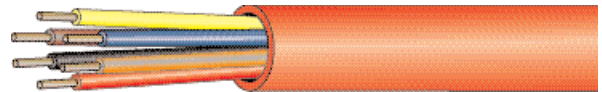

### **(NON POWER-LIMITED) CONVENTIONAL FIRE ALARM SYSTEM CABLES:**

- CONDUCTOR-
- 18 AWG or smaller AWG ( larger conductor)
  - Solid or stranded Bare copper

- INSULATION (DIELECTRIC)-
- PVC with Nylon coating • NPLF cables (Nylon for dielectric strength)
  - Fluoropolymer insulation - NPLFP cables

- SHIELD-
- (OPTIONAL) DEPENDANT ON SYSTEM REQUIREMENTS, AND ENVIRONMENTAL CONDITIONS
- To protect against interference created from other cables or other electronic/electrical/ Mechanical devices.
  - The shield is a 100% Aluminium foiled wrap.

- JACKET-
- PVC Jacket for the NPLF cables
- Fluoropolymer jacket - NPLFP cables
  - Color is usually red.

# FPLR Fire Alarm Cables

## Fire Alarm Cables Power-Limited Multiple Conductor/ Unshielded



### Description:

- ASTM bare copper • PVC insulation • Twisted pair or cabled construction • Overall PVC jacket

### Rating:

- NEC Type FPLR
- (UL) Listed
- Meets 300V requirements as specified in the NEC
- Flame Rating: UL1666

Standard pool size 1000ft.

### Applications:

Indoor for:

- Audio Circuits
- Control Circuits
- Initiating Circuits
- Notification Circuits

Catalog No.	No. of Cond.	Conductor Type & Nom. D.C.R	Insulation Type & Thickness Inches	Shielding	Jacket Type & Thickness Inches	Nom. O.D. Inches	NEC Type	Nom. Capacitance	Jacket Color
980	1 Pair	18 AWG Solid 6.5 Ω/Mft	PVC .008	None	PVC .017	.146	FPLR	29 pf/ft*	RD, BL, WH, YE
982	4	18 AWG Solid 6.5 Ω/Mft	PVC .008	None	PVC .017	.170	FPLR	29 pf/ft*	RD, BL, WH, YE
990	1 Pair	16 AWG Solid 4.1 Ω/Mft	PVC .008	None	PVC .017	.168	FPLR	32 pf/ft*	RD, BL, WH, YE
992	4	16 AWG Solid 4.1 Ω/Mft	PVC .008	None	PVC .017	.198	FPLR	32 pf/ft*	Red
994	1 Pair	14 AWG Solid 2.6 Ω/Mft	PVC .012	None	PVC .017	.210	FPLR	35 pf/ft*	RD, BL, WH, YE
700	4	14 AWG Solid 2.6 Ω/Mft	PVC .012	None	PVC .017	.246	FPLR	35 pf/ft*	Red
998	1 Pair	12 AWG Solid 1.8 Ω/Mft	PVC .012	None	PVC .017	.244	FPLR	45 pf/ft*	Red

### Special Notes:

- Selected Plenum Versions see pages 52
  - Selected Indoor/Outdoor Aquaseal Water Resistant® Versions see Aquaseal Section pg.43
  - Select Items are Packaged in our Advantage Box
  - Orange rip cord under jacket
- RANDED VERSIONS SEE PAGE 57.**

### Tracer Marks:

Available upon Request: Minimum Quantities may apply

Example:- On a Red Jacket only

**980T-GN**

T- Tracer

GN- Green Tracer

**Color Code- See page 49**

800-245-4964 • www.westpenn-wpw.com

# FPLR Fire Alarm Cables

## Fire Alarm Cables Power-Limited Multiple Conductor/ Shielded

### Applications:

Indoor for:

- Audio Circuits
- Control Circuits
- Initiating Circuits
- Notification Circuits

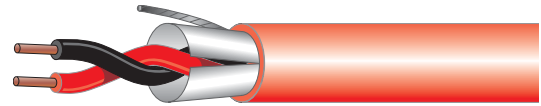

### Description:

- ASTM bare copper • PVC insulation • Twisted pair or cabled construction • Overall shield 100% coverage of aluminum polyester foil binders as required with 24 AWG TC drain wire
- Overall PVC jacket

### Rating:

- NEC Type FPLR
- (UL) Listed
- Meets 300V requirements as specified in the NEC
- Flame Rating: UL1666

Standard spool size 1000ft.

Catalog No.	No. of Cond.	Conductor Type & Nom. D.C.R	Insulation Type & Thickness Inches	Shielding & % Coverage	Jacket Type & Thickness Inches	Nom. O.D. Inches	NEC Type	Nom. Capacitance	Jacket Color
975	1 Pair	18 AWG Solid 6.5 Ω/Mft	PVC .008	Al. Foil 100%	PVC .017	.150	FPLR	73 pf/ft* 133 pf/ft**	RD, BL, WH, YE
977	4	18 AWG Solid 6.5 Ω/Mft	PVC .008	Al. Foil 100%	PVC .017	.180	FPLR	73 pf/ft* 133 pf/ft**	Red
991	1 Pair	16 AWG Solid 4.1 Ω/Mft	PVC .010	Al. Foil 100%	PVC .017	.172	FPLR	82 pf/ft* 148 pf/ft**	RD, BL, WH, YE
993	4	16 AWG Solid 4.1 Ω/Mft	PVC .008	Al. Foil 100%	PVC .017	.200	FPLR	82 pf/ft* 148 pf/ft**	Red
995	1 Pair	14 AWG Solid 2.6 Ω/Mft	PVC .012	Al. Foil 100%	PVC .017	.215	FPLR	84 pf/ft* 151 pf/ft**	Red
999	1 Pair	12 AWG Solid 1.8 Ω/Mft	PVC .012	Al. Foil 100%	PVC .017	.248	FPLR	96 pf/ft* 173 pf/ft**	Red

\* Capacitance between conductors.

\*\* Capacitance between one conductor and the other connected to the shield

Color Code	
All Cables	1.Black, 2. Red, 3. Brown, 4. Blue
	<b>JACKET:</b> RD-Red, BL-Blue, WH- White, YE-Yellow

### Tracer Marks:

Available upon Request: Minimum Quantities may apply  
Example:- On a Red Jacket only

975T-GN

T- Tracer

GN- Green Tracer

### Special Notes:

- Selected Plenum Versions see pages 53
- Selected Indoor/Outdoor Aquaseal Water Resistant® Versions see Aquaseal Section pg.44
- Select Items are Packaged in our Advantage Box.
- Orange rip cord under jacket
- **STRANDED VERSIONS SEE PAGE 58.**

800-245-4964 • www.westpenn-wpw.com

# FPLP Fire Alarm Cables

## Fire Alarm Cables Power-Limited/ Unshielded Plenecon II ® Extra Flexible



### Description:

- ASTM bare copper • Polymer alloy insulation
- Twisted pair or cabled construction • Flexible plenum jacket

### Rating:

- NEC Type FPLP
- (UL) Listed
- Meets 300V requirements as specified in the NEC
- Flame Rating: NFPA-262 Smoke & Flame Test

Standard spool size 1000ft.

### Applications:

Indoor within ducts, plenums and other spaces used for environmental air:

- Audio Circuits
- Control Circuits
- Initiating Circuits
- Notification Circuits

800-245-4964 • www.westpenn-wpw.com

Catalog No.	No. of Cond.	Conductor Type & Nom. D.C.R	Insulation Type & Thickness Inches	Shielding	Jacket Type & Thickness Inches	Nom. O.D. Inches	NEC Type	Nom. Capacitance	Jacket Color
60980B	1 Pair	18 AWG Solid 6.5 Ω/Mft	.008	None	.015	.144	FPLP	29 pf/ft*	Red
60982B	4	18 AWG Solid 6.5 Ω/Mft	.008	None	.015	.166	FPLP	29 pf/ft*	Red
60991B	1 Pair	16 AWG Solid 4.1 Ω/Mft	.008	None	.015	.164	FPLP	32 pf/ft*	RD, BL, OR, WH, YE
60164B	4	16 AWG Solid 4.1 Ω/Mft	.008	None	.015	.191	FPLP	32 pf/ft*	Red
60993B	1 Pair	14 AWG Solid 2.6 Ω/Mft	.010	None	.015	.198	FPLP	35 pf/ft*	RD, BL, YE
60700B	4	14 AWG Solid 2.6 Ω/Mft	.010	None	.015	.236	FPLP	35 pf/ft*	Red
60995B	1 Pair	12 AWG Solid 1.8 Ω/Mft	.010	None	.015	.239	FPLP	45 pf/ft*	Red

\* Capacitance between conductors.

### Special Notes:

- Plenum Installation precautions see Technical Reference Section pg.196
- Select Items are Packaged in our Advantage Box
- **STRANDED VERSIONS SEE PAGE 58.**

#### Tracer Marks:

Available upon Request: Minimum Quantities may apply  
Example:- On a Red Jacket only

60980BT-GN

T- Tracer

GN- Green Tracer

Color Code	
All Cables	1.Black, 2. Red, 3. Brown, 4. Blue
	<b>JACKET: Red</b> RD- Red, BL-Blue, OR-Orange, WH-White, YE- Yellow

# FPLP Fire Alarm Cables

## Fire Alarm Cables Power-Limited / Shielded Plenecon II ® Extra Flexible

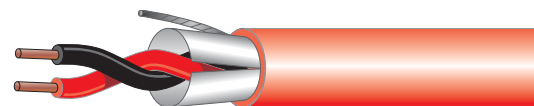

### Applications:

Indoor within ducts, plenums and other spaces used for environmental air:

- Audio Circuits
- Control Circuits
- Initiating Circuits
- Notification Circuits

### Description:

- ASTM bare copper • Polymer Alloy insulation • Twisted pair or cabled construction • Overall shield 100% coverage of aluminum polyester foil with 24 AWG TC drain wire • Flexible plenum jacket

### Rating:

- NEC Type FPLP
- (UL) Listed
- Meets 300V requirements as specified in the NEC
- Flame Rating: NFPA-262 Smoke & Flame Test

Standard spool size 1000ft.

Catalog No.	No. of Cond.	Conductor Type & Nom. D.C.R	Insulation Type & Thickness Inches	Shielding & % Coverage	Jacket Type & Thickness Inches	Nom. O.D. Inches	NEC Type	Nom. Capacitance	Jacket Color
60975B	1 Pair	18 AWG Solid 6.5 Ω/Mft	.008	Al. Foil 100%	.015	.148	FPLP	54 pf/ft* 97 pf/ft**	Red
60977B	4	18 AWG Solid 6.5 Ω/Mft	.008	Al. Foil 100%	.015	.170	FPLP	54 pf/ft* 97 pf/ft**	Red
60990B	1 Pair	16 AWG Solid 4.1 Ω/Mft	.008	Al. Foil 100%	.015	.168	FPLP	61 pf/ft* 110 pf/ft**	Red
603164B	4	16 AWG Solid 4.1 Ω/Mft	.008	Al. Foil 100%	.015	.195	FPLP	61 pf/ft* 110 pf/ft**	Red
60992B	1 Pair	14 AWG Solid 2.6 Ω/Mft	.010	Al. Foil 100%	.015	.202	FPLP	84 pf/ft* 151 pf/ft**	Red
60994B	1 Pair	12 AWG Solid 1.8 Ω/Mft	.010	Al. Foil 100%	.015	.243	FPLP	96 pf/ft* 173 pf/ft**	Red

### DATA GRADE PLENUM

D60975 ^	1 Pair	18 AWG Solid 6.5 Ω/Mft	.012	Al. Foil 100%	.015	.165	FPLP	25 pf/ft* 45 pf/ft**	Red
D60990 ^	1 Pair	16 AWG Solid 4.1 Ω/Mft	.012	Al. Foil 100%	.015	.188	FPLP	30 pf/ft* 54 pf/ft**	Red

^ - Data grade versions for addressable systems contain Low Loss Insulation and Overall Flexible Plenum Jacket.

- \* Capacitance between conductors.
- \*\* Capacitance between one conductor and the other connected to the shield

Color Code	
All Cables	1.Black, 2. Red, 3. Brown, 4. Blue
	<b>JACKET: Red</b>

### Special Notes:

- Plenum Installation precautions see Technical Reference Section pg.196

### Tracer Marks:

Available upon Request: Minimum Quantities may apply  
Example:- On a Red Jacket only

60980BT-GN

T- Tracer

GN- Green Tracer

# Stranded Fire Alarm Cables

## Stranded Conductor Fire Alarm Cables Power-Limited Multiple Conductor/ Shielded

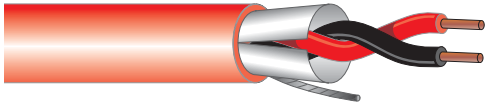

### Description:

- ASTM Stranded bare copper • Polymer Alloy insulation • Twisted pair
- Overall shield 100% coverage of aluminum polyester foil with 24 AWG TC drain wire • Flexible plenum jacket

### Rating:

- NEC Type FPLR
- (UL) Listed
- Meets 300V requirements as specified in the NEC
- Flame Rating: UL1666



### Applications:

- Indoor for:
- Audio Circuits
  - Control Circuits
  - Initiating Circuits
  - Notification Circuits

Standard spool size 1000ft.

Catalog No.	No. of Cond.	Conductor Type & Nom. D.C.R	Insulation Type & Thickness Inches	Shielding	Jacket Type & Thickness Inches	Nom. O.D. Inches	NEC Type	Nom. Capacitance	Jacket Color
995S	1 Pair	14 AWG Stranded 2.6 Ω/Mft	PVC .012	Al. Foil 100%	PVC .017	.232	FPLR	84 pf/ft* 151 pf/ft**	Red
999S	1 Pair	12 AWG Stranded 1.8 Ω/Mft	PVC .012	Al. Foil 100%	PVC .017	.264	FPLR	96 pf/ft* 173 pf/ft**	Red

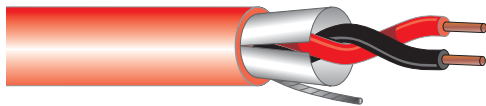

## Stranded Conductor Fire Alarm Cables Plenum Power-Limited/ Shielded Stranded Conductors Extra Flexible

### Description:

- ASTM Stranded bare copper • Polymer Alloy insulation • Twisted pair
- Overall shield 100% coverage of aluminum polyester foil with 24 AWG TC drain wire • Flexible plenum jacket

### Rating:

- NEC Type FPLP
- (UL) Listed
- Meets 300V requirements as specified in the NEC
- Flame Rating: NFPA-262 Smoke & Flame Test



### Applications:

- Plenum Indoor for:
- Audio Circuits
  - Control Circuits
  - Initiating Circuits
  - Notification Circuits

Standard spool size 1000ft.

Catalog No.	No. of Cond.	Conductor Type & Nom. D.C.R	Insulation Type & Thickness Inches	Shielding	Jacket Type & Thickness Inches	Nom. O.D. Inches	NEC Type	Nom. Capacitance	Jacket Color
60990BS	1 Pair	16 AWG Stranded 4.1 Ω/Mft	.008	Al. Foil 100%	.015	.174	FPLP	61 pf/ft* 110 pf/ft**	Red
60992BS	1 Pair	14 AWG Stranded 2.6 Ω/Mft	.010	Al. Foil 100%	.015	.210	FPLP	84 pf/ft* 151 pf/ft**	Red
60994BS	1 Pair	12 AWG Stranded 1.8 Ω/Mft	.010	Al. Foil 100%	.015	.249	FPLP	96 pf/ft* 173 pf/ft**	Red

800-245-4964 • www.westpenn-wpw.com

# Stranded Fire Alarm Cables

## Stranded Conductor Fire Alarm Cables Power-Limited Multiple Conductor/ Unshielded

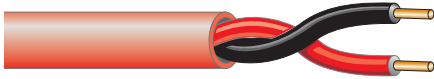

### Description:

- ASTM Stranded bare copper • PVC insulation • Twisted pair or cabled construction • Overall PVC jacket

### Rating:

- NEC Type FPLR
- (UL) Listed
- Meets 300V requirements as specified in the NEC
- Flame Rating: UL1666



### Applications:

- Indoor for:
- Audio Circuits
  - Control Circuits
  - Initiating Circuits
  - Notification Circuits

Standard pool size 1000ft.

Catalog No.	No. of Cond.	Conductor Type & Nom. D.C.R.	Insulation Type & Thickness Inches	Shielding	Jacket Type & Thickness Inches	Nom. O.D. Inches	NEC Type	Nom. Capacitance	Jacket Color
990S	1 Pair	16 AWG Strd. 4.1 Ω/Mft	PVC .009	None	PVC .017	.182	FPLR	32 pf/ft*	Red
994S	1 Pair	14 AWG Strd. 2.6 Ω/Mft	PVC .010	None	PVC .017	.224	FPLR	35 pf/ft*	Red
998S	1 Pair	12 AWG Strd. 1.8 Ω/Mft	PVC .010	None	PVC .017	.260	FPLR	45 pf/ft*	Red



## Stranded Conductor Fire Alarm Cables Plenum Power-Limited/ Unshielded Stranded Conductors Extra Flexible

### Description:

- ASTM Stranded bare copper • Polymer alloy insulation
- Twisted pair or cabled construction • Flexible plenum jacket

### Rating:

- NEC Type FPLP
- (UL) Listed
- Meets 300V requirements as specified in the NEC
- Flame Rating: NFPA-262 Smoke & Flame Test



### Applications:

- Plenum Indoor for:
- Audio Circuits
  - Control Circuits
  - Initiating Circuits
  - Notification Circuits

Standard pool size 1000ft.

Catalog No.	No. of Cond.	Conductor Type & Nom. D.C.R.	Insulation Type & Thickness Inches	Shielding	Jacket Type & Thickness Inches	Nom. O.D. Inches	NEC Type	Nom. Capacitance	Jacket Color
60991BS	1 Pair	16 AWG Stranded 4.1 Ω/Mft	.008	None	.015	.164	FPLP	32 pf/ft*	Red
60993BS	1 Pair	14 AWG Stranded 2.6 Ω/Mft	.010	None	.015	.198	FPLP	35 pf/ft*	Red
60995BS	1 Pair	12 AWG Stranded 1.8 Ω/Mft	.010	None	.015	.239	FPLP	45 pf/ft*	Red

# Fire Alarm Cables

## Fire Alarm Cables Power-Limited One & Two Conductor/ Parallel

### Applications:

Indoor for:

- Power-Limited Protective Circuits

### Description:

- ASTM bare copper • PVC insulation
- Two conductor parallel features- PERFECTSTRIPE®

### Rating:

- NEC Type FPL
- (UL) Listed
- Flame Rating: UL1685

### Parallel Construction- Two Conductor

Catalog No.	No. of Cond.	Conductor Type & Nom. D.C.R	Insulation Type & Thickness Inches	Shielding	Jacket Type & Thickness Inches	Nom. O.D. Inches	NEC Type	Nom. Capacitance	Jacket Color
970	2	18 AWG Solid 6.5 Ω/Mft	PVC .032	None	--	.104x.204	FPL	--	Red
971	2	16 AWG Solid 4.1 Ω/Mft	PVC .032	None	--	.115x.225	FPL	--	Red
972	2	14 AWG Solid 2.6 Ω/Mft	PVC .032	None	--	.128x.250	FPL	--	Red

### Colors

Jacket Colors	Red
---------------	-----

### NOTE:

Additional Colored Jackets are available upon request.

Minimum quantity orders may apply.

- Items are Packaged in our Advantage Box

800-245-4964 • www.westpenn-wpw.com

# NPLF Fire Alarm Cables

## Fire Alarm Cables Nonpower-Limited/ Unshielded

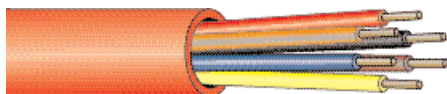

### Description:

- ASTM bare copper • PVC insulation with Nylon
- Overall PVC jacket

### Rating:

- NEC Type NPLF
- (UL) Listed
- Meets 150V requirements as specified in the NEC
- Flame Rating: UL1685

### Applications:

- Indoor for:
- Audio Circuits
  - Control Circuits
  - Initiating Circuits
  - Notification Circuits

Standard pool size 1000ft.

Catalog No.	No. of Cond.	Conductor Type & Nom. D.C.R	Insulation Type & Thickness	Shielding	Jacket Type & Thickness	Nom. O.D. Inches	NEC Type	Nom. Capacitance	Jacket Color
			Inches		Inches				
1990	1 Pair	16 AWG Solid 4.1 Ω/Mft	PVC .016 Nylon .005	None	PVC .037	.252	NPLF	--	Red
1994	1 Pair	14 AWG Solid 2.6 Ω/Mft	PVC .016 Nylon .005	None	PVC .037	.278	NPLF	--	Red

### Rating:

- NEC Type NPLF
- (UL) Listed
- Flame Rating: UL1685

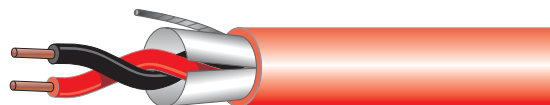

Standard pool size 1000ft.

Catalog No.	No. of Cond.	Conductor Type & Nom. D.C.R	Insulation Type & Thickness	Shielding & % Coverage	Jacket Type & Thickness	Nom. O.D. Inches	NEC Type	Nom. Capacitance	Jacket Color
			Inches		Inches				
1975	1 Pair	18 AWG Solid 6.5 Ω/Mft	PVC .016 Nylon .005	Al. Foil 100%	PVC .037	.244	NPLF	52 pf/ft* 94 pf/ft**	Red
1991	1 Pair	16 AWG Solid 4.1 Ω/Mft	PVC .016 Nylon .005	Al. Foil 100%	PVC .037	.264	NPLF	57 pf/ft* 103 pf/ft**	Red
1995	1 Pair	14 AWG Solid 2.6 Ω/Mft	PVC .016 Nylon .005	Al. Foil 100%	PVC .037	.284	NPLF	64 pf/ft* 115 pf/ft**	Red

- \* Capacitance between conductors.  
\*\* Capacitance between one conductor and the other connected to the shield

### Special Notes:

- Orange rip cord under jacket

Color Code	
All Cables	1.Black, 2. Red
	JACKET: Red

800-245-4964 • www.westpenn-wpw.com

## **ADDRESSABLE FIRE ALARM SYSTEM**

Addressable Fire Alarm Systems differ from conventional systems in a number of ways and certainly add more flexibility, intelligence, speed of identification and scope of control. For this reason, Addressable Fire Alarm Systems are the natural choice for larger premises and buildings with more complex system requirements.

In an Addressable system, detectors are wired in a loop around the building with each detector having its own unique address. The system may contain one or more loops depending upon the size of the system and design requirements. The Fire Control Panel communicates with each detector individually and receives a status report e.g. Normal, Alarm, Trouble etc. As each detector has an individual address the fire alarm control panel is able to display or indicate the precise location of the device in question, which obviously helps speed the location of an incident and for this reason zoning of the system is not necessary, although it may be done for convenience.

Addressable detectors are, in themselves, intelligent devices which are capable of reporting far more than just fire or fault conditions. Most analog addressable detectors are able to signal if contamination in the device reaches a pre-set level enabling maintenance to take place prior to problems being experienced.

In most earlier styles of Addressable systems, the notification appliances were not intelligent. Today, many manufacturers are providing addressable notification technology. There are many advantages of providing such technology. Such as lower cost of wire, and overall installation time.

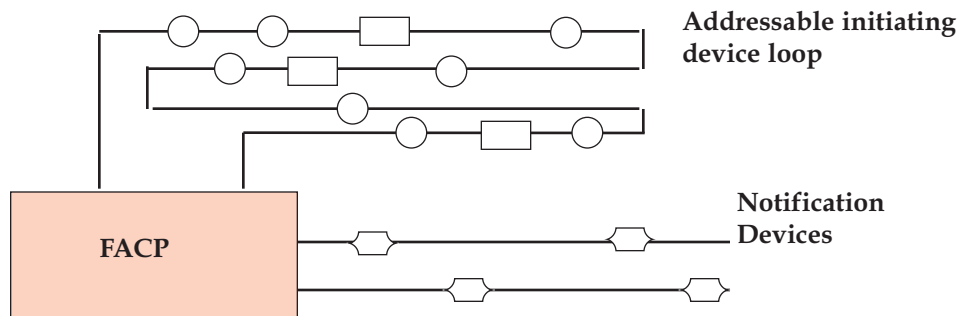

## **ADDRESSABLE FIRE ALARM CABLE SELECTION**

The designer must be aware of not only the D.C Resistance of the cable, but the capacitance and the Velocity of propagation of the cable. The designer must assure that the overall loop capacitance is not compromised, and error rates are kept to a minimum.

Nominal Capacitance for wire sizes:

18 AWG solid unshielded:	16pf/ft
18 AWG solid shielded:	25pf/ft t45pf/ft **
16 AWG solid unshielded:	18pf/ft
16 AWG solid shielded:	30pf/ft 54pf/ft **
14 AWG solid shielded:	30pf/ft. 54pf/ft **
12 AWG solid shielded:	35pf/ft. 63pf/ft ****

Capacitance between one conductor and the other connected to the shield.

Notes:

- If Class A wiring is installed, the wire length may be up to 4 times the single wire length in this calculation
- Consult your panel manufacturer's specifications to determine acceptable loop capacitance.
- All wiring must be installed in compliance with the National Electrical Code (NEC) and applicable local codes, as well as special requirements of the authority having jurisdiction, using the proper wire size.

## **LOW AND MID CAPACITANCE CABLES: ADDRESSABLE FIRE ALARM SYSTEM**

The need to conform to the American with Disability Act (ADA), and the increased demand for addressable fire-alarm systems have created many changes in the fire-alarm cable constructions. An addressable system allows the control panel or unit to communicate with each base individually using a sophisticated polling process. The polling process allows the system to detect trouble, or alarm for each base initiating devices, and in some cases the notification devices. Addressable fire-alarm signals need to be fast and have a clear signal transfer. Hence the electrical characteristics are a major concern in cable construction

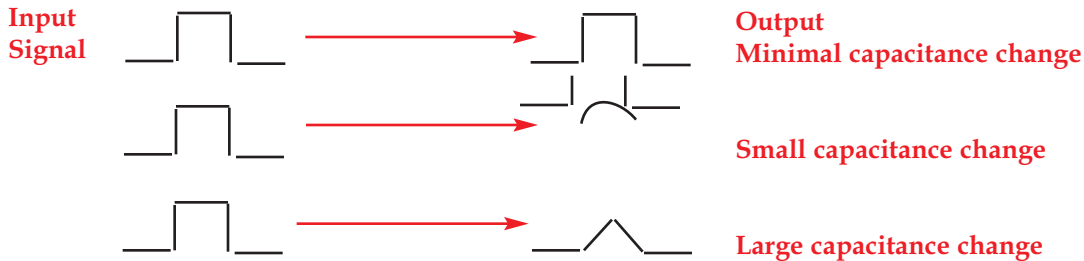

**Capacitance**-The property of a system of conductors and dielectrics that allow the storage of an electrical charge when a potential difference exists between conductors. Capacitance is found between two wires of a twisted pair, and also between adjacent conductors in the same cable (mutual capacitance). Capacitance is expressed in pf/ft. The larger the capacitance, the higher the distortions.

**Velocity of propagation**-refers to a ratio of a signal traveling through a cable compared to that same signal traveling through air and is determined by the dielectric insulation material.

## **(POWER-LIMITED) ADDRESSABLE FIRE ALARM SYSTEM CABLES:**

### CONDUCTOR

- Shall not be smaller in size than a 26 AWG.
- Single conductor no smaller than 18 AWG.
- Solid or Stranded conductor. Bare Copper for lower DC Resistance.
- West Penn Wire 12 AWG up to 18 AWG.

### INSULATION (DIELECTRIC)

- COPOLENE Insulation for the FPL cables.
  - Thicker than conventional fire system cable insulation
  - A better performance dielectric material
  - Fluoropolymer Insulation for the FPLP Cables
- TWISTED CABLE CONSTRUCTION.**

### SHIELD-

(OPTIONAL) DEPENDANT ON SYSTEM REQUIREMENTS, AND ENVIRONMENTAL CONDITIONS.

- To protect against interference created from other cables or other electronic/electrical/ Mechanical devices.
- The shield is a 100% Aluminium foiled wrap.
- JACKET
- PVC Jacket for the FPL cables
- Flexible Plenum PVC jacket for the FPLP cables.

# Fire Alarm Cables

## Power-Limited / Unshielded Addressable Systems/ Data Cable

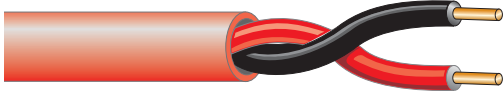

### Description:

- ASTM bare copper • Polyolefin insulation • Short overall twist lengths • Unshielded construction • Overall PVC jacket

### Rating:

- NEC Type FPLR
- (UL) Listed
- Meets 300V requirements as specified in the NEC
- Flame Rating: UL1666

### Applications:

Indoor data cable for:

- Data Circuits
- Addressable Systems
- Initiating Circuits
- Notification Circuits

Standard pool size 1000ft.

Catalog No.	No. of Cond.	Conductor Type & Nom. D.C.R	Insulation Type & Thickness Inches	Shielding	Jacket Type & Thickness Inches	Nom. O.D. Inches	NEC Type	Nom. Capacitance	Jacket Color
D980	1 Pair	18 AWG Solid 6.5 Ω/Mft	Polyolefin .015	None	PVC .030	.182	FPLR	16 pf/ft*	Red
D990	1 Pair	16 AWG Solid 4.1 Ω/Mft	Polyolefin .015	None	PVC .030	.223	FPLR	18 pf/ft*	Red

\* Capacitance between conductors.

## Power-Limited / Shielded Addressable Systems/ Data Cable

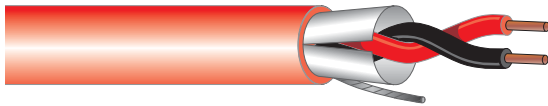

### Description:

- ASTM bare copper • Polyolefin insulation • Short overall twist length • Overall shield 100% coverage of aluminum polyester foil with 24 AWG TC drain wire • Overall PVC jacket

Standard pool size 1000ft.

Catalog No.	No. of Cond.	Conductor Type & Nom. D.C.R	Insulation Type & Thickness Inches	Shielding & % Coverage	Jacket Type & Thickness Inches	Nom. O.D. Inches	NEC Type	Nom. Capacitance	Jacket Color
D975	1 Pair	18 AWG Solid 6.5 Ω/Mft	Polyolefin .015	Al. Foil 100%	PVC .030	.210	FPLR	25 pf/ft* 45 pf/ft**	Red
D991	1 Pair	16 AWG Solid 4.1 Ω/Mft	Polyolefin .015	Al. Foil 100%	PVC .030	.226	FPLR	30 pf/ft* 54 pf/ft**	Red
D995	1 Pair	14 AWG Solid 2.6 Ω/Mft	Polyolefin .020	Al. Foil 100%	PVC .030	.262	FPLR	30 pf/ft* 54 pf/ft**	Red

\* Capacitance between conductors.

\*\* Capacitance between one conductor and the other connected to the shield

Color Code	
All Cables	1.Black, 2. Red, 3. Brown, 4. Blue
	<b>JACKET: Red</b>

### Special Notes:

- Selected Plenum Versions see pages 53
- Orange rip cord under jacket

# AQUASEAL WATER RESISTANT CABLE



Aquaseal Power-limited water-resistant cables are designed to be used for indoor/outdoor fire alarm system. The Aquaseal products are manufactured using a premium grade jacket compound. These cables are flame retardant, sunlight and water resistant, and employ an abrasion and crush resistant construction. This durability allows the Aquaseal power-limited water-resistant cables to be direct burial.

The internal cable construction employs a dry water blocking barrier instead of a messy gel. Unlike many other outdoor cables which can not be placed indoors due to their inability to pass flame tests, Aquaseal water-resistant cables carry both indoor and outdoor ratings.

Aquaseal cable retains consistent electrical characteristics compared to standard cable when immersed in water. The moisture blocking barrier used in this cable has proven itself in various tests where standard outdoor cable has failed. This can be verified by monitoring the capacitance levels of both cables. Aquaseal water-resistant cables will consistently have lower capacitance values and remain stable over the long haul enabling the lowest signal loss.

Aquaseal is UL listed NEC type FPL or PLTC rated and utilizing 18 AWG to 12 AWG makes this cable excellent for low voltage Conventional and Addressable systems.

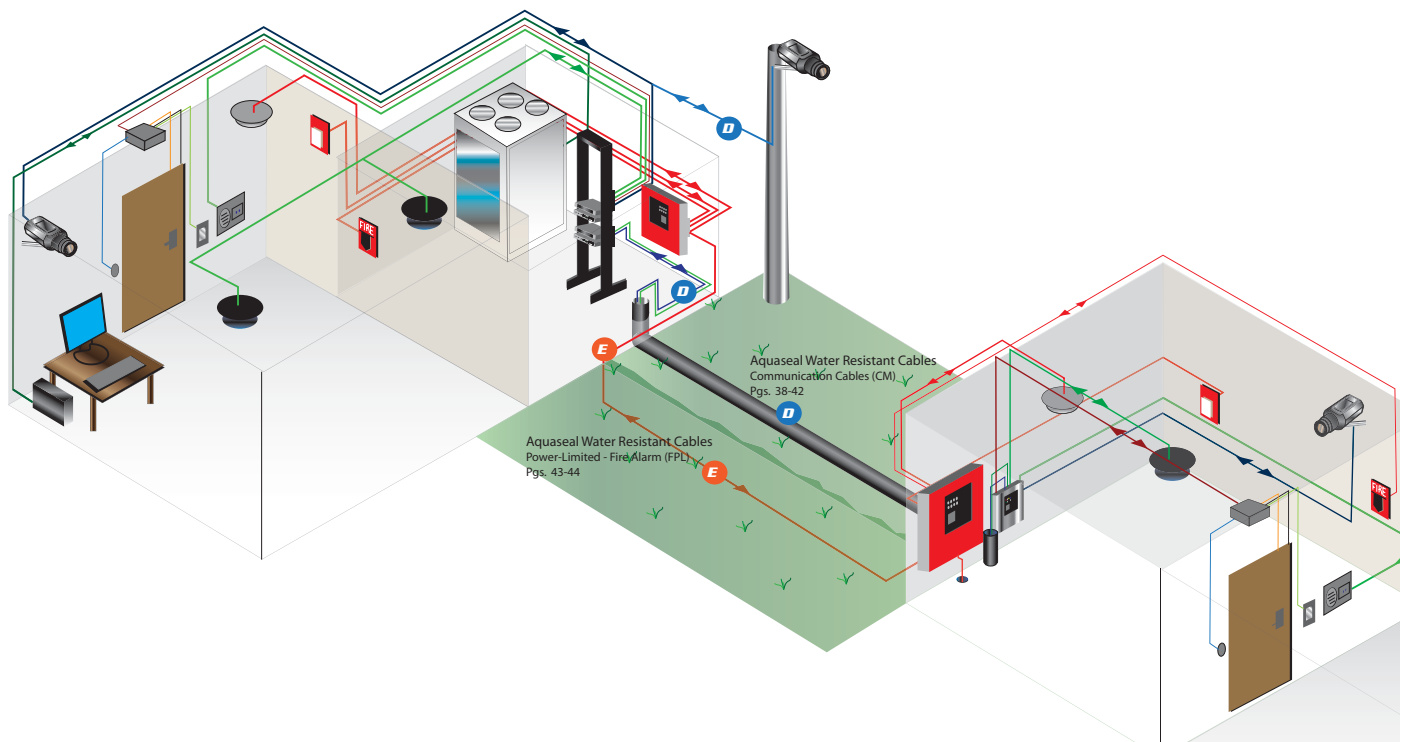

# Aquaseal Cables

## Aquaseal® Water Blocking Cable Multi-Conductor/ 300 Volts Power-Limited Shielded

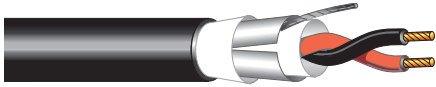

### Description:

- ASTM Bare Copper • PVC insulation with Nylon • Twisted pair or cabled construction • Overall shield 100% coverage of aluminum polyester foil with drain wire • Waterblocked Construction
- Overall Sunlight/ Moisture Resistant PVC jacket

### Rating:

- NEC Type FPL or PLTC or CL3
- (UL) Listed
- Meets 300V requirements as specified in the NEC
- Direct Burial
- Flame Rating: UL1685

### Applications:

#### Indoor/Outdoor Use:

- Low Voltage Industrial Process Control
- Power-Limited Circuits
- Power-Limited Fire Alarm Circuits
- Power-Limited Tray Cable PLTC
- Line Level Audio

**Direct Burial**

Standard pool size 1000ft.

Catalog No.	No. of Cond.	Conductor Type & Nom. D.C.R	Insulation Type & Thickness	Shielding % Coverage	Jacket Type & Thickness	Nom. O.D. Inches	NEC Type	Nom. Capacitance	Jacket Color
			Inches		Inches				
AQ293	1 Pair	18 AWG (7x26) 6.2Ω/Mft	PVC .015 Nylon .005	Al. Foil-100% 24 Strd.	.040	.310	CL3/FPL PLTC	32 pf/ft* 58 pf/ft**	Black
AQ3244	4	18 AWG (7x26) 6.2Ω/Mft	PVC .015 Nylon .005	Al. Foil-100% 24 Strd.	.040	.371	CL3/FPL PLTC	32 pf/ft* 58 pf/ft**	Black
AQ294	1 Pair	16 AWG (7x24) 4.2Ω/Mft	PVC .015 Nylon .005	Al. Foil-100% 24 Strd.	.040	.328	CL3/FPL PLTC	37 pf/ft* 67 pf/ft**	Black
AQ3245	4	16 AWG (7x24) 4.2Ω/Mft	PVC .015 Nylon .005	Al. Foil-100% 24 Strd.	.050	.415	CL3/FPL PLTC	37 pf/ft* 67 pf/ft**	Black
AQ295	1 Pair	14 AWG (19x27) 2.7Ω/Mft	PVC .015 Nylon .005	Al. Foil-100% 24 Strd.	.040	.350	CL3/FPL PLTC	46 pf/ft* 83 pf/ft**	Black
AQ296	2	12 AWG (19x25) 1.7Ω/Mft	PVC .015 Nylon .005	Al. Foil-100% 24 Strd.	.040	.375	CL3/FPL PLTC	54 pf/ft* 97 pf/ft**	Black

\* Capacitance between conductors.

\*\* Capacitance between one conductor and the other connected to the shield

### Special Notes:

- Aquaseal Water Resistant Cables is a Registered Trademark of West Penn Wire
- Orange ripcord under jacket



Color Code	
All Cables	1. Black, 2. Red, 3. Brown, 4. Blue
	JACKET: Black

800-245-4964 • www.westpenn-wpw.com

# Aquaseal Cables

## Aquaseal® Water Blocking Cable Multi-Conductor/ 300 Volts Power-Limited



### Applications:

#### Indoor/Outdoor Use:

- Low Voltage Industrial Process Control
- Power-Limited Circuits
- Power-Limited Fire Alarm Circuits
- Power-Limited Tray Cable PLTC
- Speaker Level

Direct Burial

### Description:

- ASTM Bare Copper • PVC insulation with nylon • Twisted pair or cabled construction • Waterblocked Construction • Overall Sunlight/ Moisture Resistant PVC jacket

### Rating:

- NEC Type FPL or PLTC or CL3
- (UL) Listed
- Meets 300V requirements as specified in the NEC
- Direct Burial
- Flame Rating: UL1685

Standard spool size 1000ft.

Catalog No.	No. of Cond.	Conductor Type & Nom. D.C.R	Insulation Type & Thickness Inches	Shielding	Jacket Type & Thickness Inches	Nom. O.D. Inches	NEC Type	Nom. Capacitance	Jacket Color
AQ224	1 Pair	18 AWG (7x26) 6.2 Ω/Mft	PVC .015 Nylon .005	None	.035	.270	CL3/FPL PLTC	25 pf/ft*	Black
AQ244	4	18 AWG (7x26) 6.2 Ω/Mft	PVC .015 Nylon .005	None	.040	.327	CL3/FPL PLTC	25 pf/ft*	Black
AQ225	1 Pair	16 AWG (7x24) 4.2 Ω/Mft	PVC .015 Nylon .005	None	.040	.295	CL3/FPL PLTC	28 pf/ft*	Black
AQ245	4	16 AWG (7x24) 4.2 Ω/Mft	PVC .015 Nylon .005	None	.040	.355	CL3/FPL PLTC	28 pf/ft*	Black
AQ226	1 Pair	14 AWG (19x27) 2.7 Ω/Mft	PVC .015 Nylon .005	None	.040	.310	CL3/FPL PLTC	32 pf/ft*	Black
AQ246	4	14 AWG (19x27) 2.7 Ω/Mft	PVC .015 Nylon .005	None	.040	.395	CL3/FPL PLTC	32 pf/ft*	Black
AQ227	1 Pair	12 AWG (19x25) 1.7 Ω/Mft	PVC .015 Nylon .005	None	.040	.340	CL3/FPL PLTC	36 pf/ft*	Black

\* Capacitance between conductors.

Color Code	
All Cables	1. Black, 2. Red, 3. Brown, 4. Blue
	<b>JACKET:</b> Black

### Special Notes:

- Aquaseal Water Resistant Cables is a Registered Trademark of West Penn Wire
- Orange ripcord under jacket

800-245-4964 • www.westpenn-wpw.com

## ***CIRCUIT INTEGRITY FIRE ALARM CABLES***

EVAC (Emergency Voice/Alarm Communication) systems are employed in large commercial buildings where in the event of a fire or other emergency messages will warn occupants of the emergency and, if necessary, guide the occupants out of the building in a timely and orderly way.

To do this, EVAC systems must remain operational longer than a total evacuation scenario or, as defined by code, for two hours.

### **CI vs. CIC Cables:**

CI cables have been tested to pass the 2 hour UL2196 Flame Test not in conduit. CI cables can not be deployed into conduit and pass the 2 hour flame test, therefore they are riser rated.

CIC cables have been tested to pass the 2 hour Flame Test in Conduit, therefore can be placed in a Plenum space. CIC cables cannot be deployed in a 2 hour application outside the conduit.

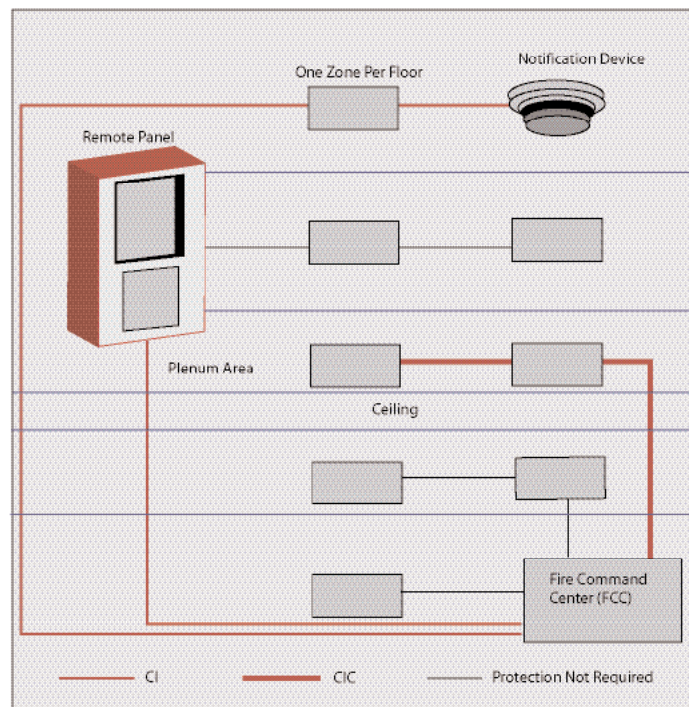

# Fire Alarm Cables

## Circuit Integrity in Conduit/ Shielded (CIC) - Riser Rated

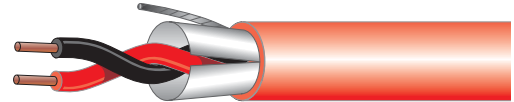

### Applications:

Indoor for:

- Circuit Integrity
- Fire Alarm Circuit Integrity
- Survivability

### Description:

- ASTM bare copper • Ceramifiable Silicon Rubber (CSR) Insulation • Twisted pair or cabled construction • Overall shield 100% coverage of aluminum polyester foil with TC drain wire • Overall FRPE Low-Smoke, Non-Halogen Jacket

### Rating:

- NEC Type FPLR
- (UL) Listed
- Meets 300V requirements as specified in the NEC - 105°C
- Flame Rating: UL1666, UL2196 - 2 Hour Flame Test ( in conduit only)

Standard spool size 1000ft.

Catalog No.	No. of Cond.	Conductor Type & Nom. D.C.R.	Insulation Type & Thickness Inches	Shielding & % Coverage	Jacket Type & Thickness Inches	Nom. O.D. Inches	NEC Type	Nom. Capacitance	Jacket Color
5200FZ	2	16 AWG 7x24 4.0 Ω/Mft	CSR .035	Al. Foil 100%	FRPE .056	.37	FPLR	22pf/ft*	Red
5220FZ	2	16 AWG Solid 4.0 Ω/Mft	CSR .035	Al. Foil 100%	FRPE .056	.36	FPLR	20pf/ft*	Red
5222FZ	4	16 AWG Solid 4.0 Ω/Mft	CSR .035	Al. Foil 100%	FRPE .056	.41	FPLR	16pf/ft*	Red
5100FZ	2	14 AWG 7x22 2.5 Ω/Mft	CSR .035	Al. Foil 100%	FRPE .056	.41	FPLR	26pf/ft*	Red
5120FZ	2	14 AWG Solid 2.5 Ω/Mft	CSR .035	Al. Foil 100%	FRPE .056	.38	FPLR	23pf/ft*	Red
5000FZ	2	12 AWG 7x20 1.6 Ω/Mft	CSR .035	Al. Foil 100%	FRPE .056	.44	FPLR	27pf/ft*	Red

\* Capacitance between conductors.

Color Code	
All Cables	Black, Red- 4 or more are Black and numbered
	<b>JACKET: Red</b>

### Special Notes:

- CSR- Ceramifiable Silicon Rubber
- FRPE- Flame Retardant Polyethylene
- CIC Cables have been tested to pass the 2 hour UL2196 Flame test in conduit. CIC cables can not be deployed outside the conduit and maintain a CI rating.

# Fire Alarm Cables

## Circuit Integrity in Conduit/ Unshielded Riser Rated - (CIC)



### Description:

- ASTM bare copper • Ceramifiable Silicon Rubber (CSR) Insulation • Twisted pair or cabled construction
- Overall FRPE Low-Smoke, Non-Halogen Jacket

### Rating:

- NEC Type FPLR
- (UL) Listed
- Meets 300V requirements as specified in the NEC - 105°C
- Flame Rating: UL 1666, UL2196 - Two Hour Flame Test ( in conduit only)

### Applications:

Indoor for:

- Circuit Integrity
- Fire Alarm Circuit Integrity
- Survivability

Standard pool size 1000ft.

Catalog No.	No. of Cond.	Conductor Type & Nom. D.C.R	Insulation Type & Thickness Inches	Shielding	Jacket Type & Thickness Inches	Nom. O.D. Inches	NEC Type	Nom. Capacitance	Jacket Color
5200UZ	2	16 AWG 7x24 4.0 Ω/Mft	CSR .035	None	FRPE .056	.37	FPLR	16pf/ft*	Red
5220UZ	2	16 AWG Solid 4.0 Ω/Mft	CSR .035	None	FRPE .056	.35	FPLR	15pf/ft*	Red
5100UZ	2	14 AWG 7x22 2.5 Ω/Mft	CSR .035	None	FRPE .056	.40	FPLR	18pf/ft*	Red
5120UZ	2	14 AWG Solid 2.5 Ω/Mft	CSR .035	None	FRPE .056	.38	FPLR	17pf/ft*	Red

\* Capacitance between conductors.

### Special Notes:

- CSR- Ceramifiable Silicon Rubber
- FRPE- Flame Retardant Polyethylene
- CIC Cables have been tested to pass the 2 hour UL2196 Flame test in conduit. CIC cables can not be deployed outside the conduit and maintain a CI rating.

Color Code	
All Cables	Black, Red
	JACKET: Red

800-245-4964 • www.westpenn-wpw.com

# Fire Alarm Cables

## Circuit Integrity/ Shielded (CI) - Riser Rated

### Applications:

Indoor for:

- Circuit Integrity
- Fire Alarm Circuit Integrity
- Survivability

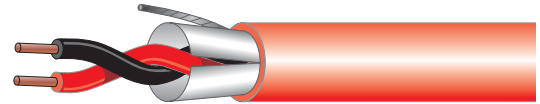

### Description:

- ASTM bare copper • Ceramifiable Silicon Rubber (CSR) Insulation • Twisted pair or cabled construction
- Overall shield 100% coverage of aluminum polyester foil with TC drain wire • Overall FRPE Low-Smoke, Non Halogen Jacket

### Rating:

- NEC Type FPLR-CI
- (UL) Listed
- Meets 300V requirements as specified in the NEC - 105°C
- Flame Rating: UL1666, UL2196 - 2 Hour Flame Test

Standard pool size 1000ft.

Catalog No.	No. of Cond.	Conductor Type & Nom. D.C.R	Insulation	Shielding	Jacket Type &	Nom. O.D. Inches	NEC Type	Nom. Capacitance	Jacket Color
			Type & Thickness Inches	& % Coverage	Thickness Inches				
5320FM	2	18 AWG Solid 5.9 Ω/Mft	CSR .034	Al. Foil 100%	FRPE .045	.31	FPLR-CI	27pf/ft*	Red
5322FM	4	18 AWG Solid 5.9 Ω/Mft	CSR .034	Al. Foil 100%	FRPE .045	.36	FPLR-CI	27pf/ft*	Red
5300FM	2	18 AWG 7x26 5.9 Ω/Mft	CSR .034	Al. Foil 100%	FRPE .045	.32	FPLR-CI	27pf/ft*	Red
5302FM	4	18 AWG 7x26 5.9 Ω/Mft	CSR .034	Al. Foil 100%	FRPE .045	.37	FPLR-CI	27pf/ft*	Red
5220FM	2	16 AWG Solid 4.0 Ω/Mft	CSR .034	Al. Foil 100%	FRPE .045	.33	FPLR-CI	31pf/ft*	Red
5222FM	4	16 AWG Solid 4.0 Ω/Mft	CSR .034	Al. Foil 100%	FRPE .045	.38	FPLR-CI	31pf/ft*	Red
5200FM	2	16 AWG 7x24 4.0 Ω/Mft	CSR .034	Al. Foil 100%	FRPE .045	.35	FPLR-CI	31pf/ft*	Red
5120FM	2	14 AWG Solid 2.5 Ω/Mft	CSR .034	Al. Foil 100%	FRPE .045	.36	FPLR-CI	33pf/ft*	Red
5122FM	4	14 AWG Solid 2.5 Ω/Mft	CSR .034	Al. Foil 100%	FRPE .045	.41	FPLR-CI	33pf/ft*	Red
5100FM	2	14 AWG 7x22 2.5 Ω/Mft	CSR .034	Al. Foil 100%	FRPE .045	.38	FPLR-CI	33pf/ft*	Red
5020FM	2	12 AWG Solid 1.6 Ω/Mft	CSR .034	Al. Foil 100%	FRPE .045	.39	FPLR-CI	37pf/ft*	Red
5022FM	4	12 AWG Solid 1.6 Ω/Mft	CSR .034	Al. Foil 100%	FRPE .045	.46	FPLR-CI	37pf/ft*	Red

Notes: Color Code Pg. 60

\* Capacitance between conductors.

800-245-4964 • www.westpenn-wpw.com

# Fire Alarm Cables



## Description:

- ASTM bare copper • Ceramifiable Silicon Rubber (CSR) Insulation • Twisted pair or cabled construction
- Overall FRPE Low-Smoke, Non-Halogen Jacket

## Rating:

- NEC Type FPLR-CI
- (UL) Listed
- Meets 300V requirements as specified in the NEC - 105°C
- Flame Rating: UL 1666, UL2196- Two Hour Flame Test

Standard pool size 1000ft.

## Circuit Integrity / Unshielded Riser Rated - (CI)

### Applications:

- Indoor for:
  - Circuit Integrity
  - Fire Alarm Circuit Integrity
  - Survivability

Catalog No.	No. of Cond.	Conductor Type & Nom. D.C.R	Insulation Type & Thickness Inches	Shielding	Jacket Type & Thickness Inches	Nom. O.D. Inches	NEC Type	Nom. Capacitance	Jacket Color
5320UM	2	18 AWG Solid 5.9 Ω/Mft	CSR .034	None	FRPE .045	.31	FPLR-CI	17pf/ft*	Red
5322UM	4	18 AWG Solid 5.9 Ω/Mft	CSR .034	None	FRPE .045	.35	FPLR-CI	17pf/ft*	Red
5220UM	2	16 AWG Solid 4.0 Ω/Mft	CSR .034	None	FRPE .045	.33	FPLR-CI	19pf/ft*	Red
5222UM	4	16 AWG Solid 4.0 Ω/Mft	CSR .034	None	FRPE .045	.38	FPLR-CI	19pf/ft*	Red
5120UM	2	14 AWG Solid 2.5 Ω/Mft	CSR .034	None	FRPE .045	.36	FPLR-CI	21pf/ft*	Red
5122UM	4	14 AWG Solid 2.5 Ω/Mft	CSR .034	None	FRPE .045	.41	FPLR-CI	21pf/ft*	Red
5020UM	2	12 AWG Solid 1.6 Ω/Mft	CSR .034	None	FRPE .045	.39	FPLR-CI	23pf/ft*	Red
5022UM	4	12 AWG Solid 1.6 Ω/Mft	CSR .034	None	FRPE .045	.45	FPLR-CI	23pf/ft*	Red

\* Capacitance between conductors.

## Special Notes:

- CSR- Ceramifiable Silicon Rubber
- FRPE- Flame Retardant Polyethylene
- CI Cables have been tested to pass the 2 hour UL2196 Flame test not in conduit. CI rated cables can not be deployed in conduit and maintain a CI rating.

Color Code	
All Cables	Black, Red- 4 or more are Black and numbered
	JACKET: Red

800-245-4964 • www.westpenn-wpw.com

## **SYSTEM LAYOUTS:**

The initiating circuits that connect detectors to a control panel should be supervised so that a fault (trouble) condition that could interfere with the proper operation of the circuit will be detected and annunciated.

Detectors are generally categorized as either 2-wire or 4-wire detectors. Two-wire detectors derive their power directly from the same fire alarm control panel alarm initiating device circuit over which they report an alarm. Because of their dependency on the initiating circuit, 2-wire detectors must be tested and listed for compatibility with the control panel to be used, to ensure proper operation.

Four-wire detectors are powered from a separate pair of wires, and like the 2-wire detector, apply an electrical short across the associated alarm initiating device to transmit an alarm. Because they do not derive their power from the alarm control panel circuit, compatibility is predicated upon the operating parameters of the power supply to which the detectors are connected and not the initiating circuit. Supervision of the power to 4-wire detectors is mandated through the use of an end of line power supervision relay (EOLR). When power is on, the relay contacts at the end of line relay are closed and connected in series with the end of line resistors beyond the last initiating device. Loss of power at any point in the power supply circuit will cause the relay to de-energize and a trouble condition to occur on the initiating circuit.

**CLASS B CIRCUITS:** Class B circuits differentiate between short circuits across the loop (alarm) and opens on the loop (trouble). Supervision of this circuit is accomplished by passing a low current through the installation wiring and an EOLR. Increases or decreases in this supervisory current are monitored by the fire alarm control panel and will cause alarm or trouble conditions, respectively, to be indicated. A single open in a Class B circuit disables all devices electrically beyond open.

**CLASS A CIRCUITS:** Class A circuits also differentiate between short circuits across the loop and opens on the loop. Supervision is accomplished by monitoring the level of current passing through the installation wiring and the EOLR, which in a Class A circuit is an integral part of the fire alarm control panel. Class A wiring must return to and be terminated in the control panel. This technique requires a minimum of four wires be terminated in the control panel, and further requires that the fire alarm control panel is designed to monitor Class A circuits. The additional circuitry necessary for Class A supervision enables the control panel to "condition" the initiating circuit to monitor the initiating circuit from both ends when in a trouble mode due to an open fault on the loop. This "conditioning" ensures that all devices are capable of responding and reporting an alarm despite a single open or non-simultaneous single ground fault on a circuit conductor.

## FIRE ALARM SYSTEM MANUFACTURERS

Edwards System Technology ( EST) [www.est.net](http://www.est.net)

Faraday Fire [www.faradayllc.com](http://www.faradayllc.com)

Fenwal Fire [www.fenwalfire.com](http://www.fenwalfire.com)

Fike Fire Alarm [www.fike.com](http://www.fike.com)

Fire Control Instruments [www.firecontrolinstruments.com](http://www.firecontrolinstruments.com)

Fire-Lite Alarms [www.firelite.com](http://www.firelite.com)

Gamewell [www.gamewell.com](http://www.gamewell.com)

Harrington Signal [www.harringtonfire.com](http://www.harringtonfire.com)

Hochiki [www.hochiki.com](http://www.hochiki.com)

Notifier [www.notifier.com](http://www.notifier.com)

Secutron [www.secutron.com](http://www.secutron.com)

Sentrol [www.sentrol.com](http://www.sentrol.com)

Siemens Cerberus [www.sbt.siemens.com](http://www.sbt.siemens.com)

Silent Knight [www.silentknight.com](http://www.silentknight.com)

Simplex Grinnell [www.simplexgrinnell.com](http://www.simplexgrinnell.com)

System Sensor [www.systemsensor.com](http://www.systemsensor.com)